

# SETUP SHEET TC4 International

<b>NAME/</b> Marc Fischer	<b>MOTOR</b> EVO 4 12x3 02er Kohlen	<b>TIRE(F)</b> Graupner 5055.72, soft Einlage 96376
<b>DATE/</b> 04.02.2001	Timing 6mm 0.55 Federn	<b>TIRE(R)</b> Graupner 5055.72, soft Einlage 96376
<b>CIRCUIT/</b> Teppich Halle Geilenkirchen	<b>SPEEDO</b> V12XC Turbo 0.55 80A	<b>TEMP/</b> 22 °C Auf 24mm Felgen

**Front**  
Vorne

A= 2 mm  
B= 160 mm

---

**Rear**  
Hinten

C= 2 mm  
D= 160 mm

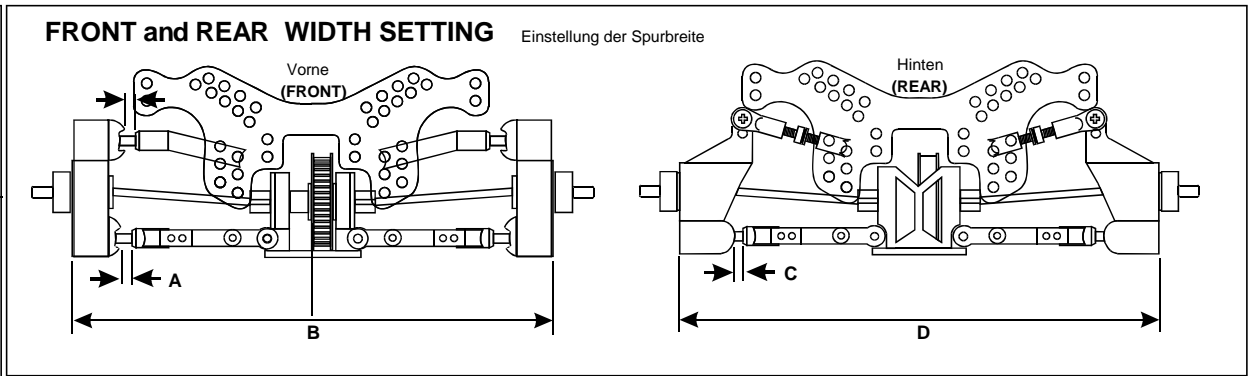

**Front**  
Vorne

A= 8 mm

---

**Rear**  
Hinten

B= 8 mm

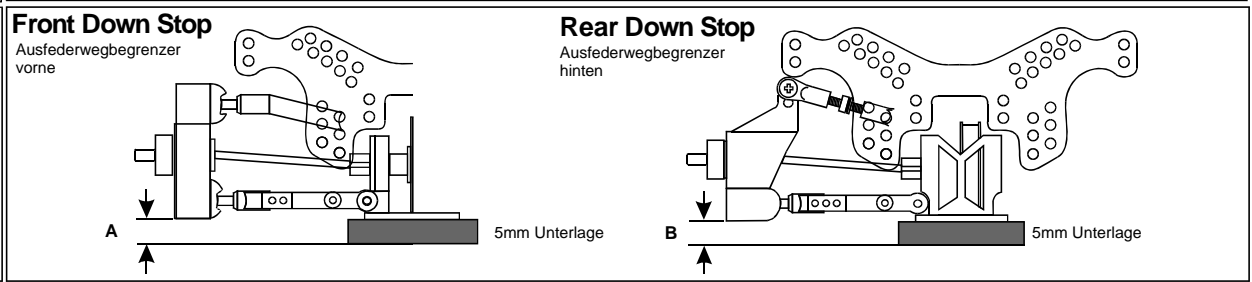

**Front**  
Vorne

F.L 1.0° + - N

F.R 1.0° + - N

---

**Rear**  
Hinten

R.L 1.0° + - N

R.R 1.0° + - N

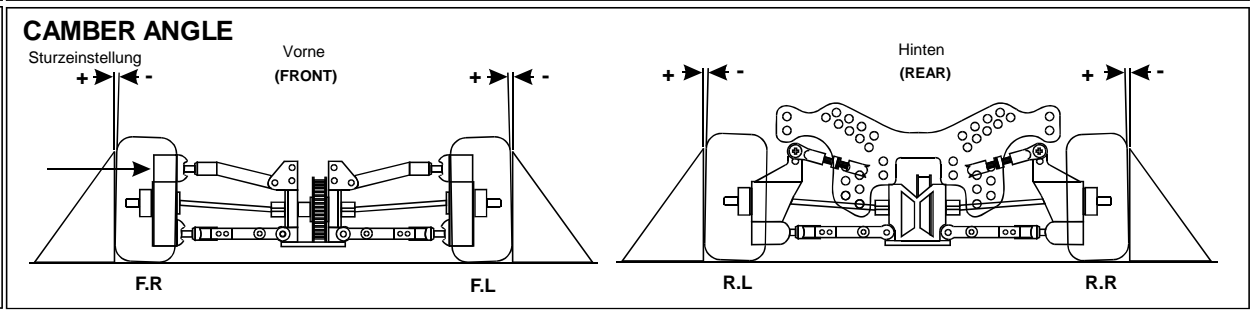

**Front**  
Vorne

0.0° + - N

0.0° + - N

---

**Rear**  
Hinten

1.0° + - N

1.0° + - N

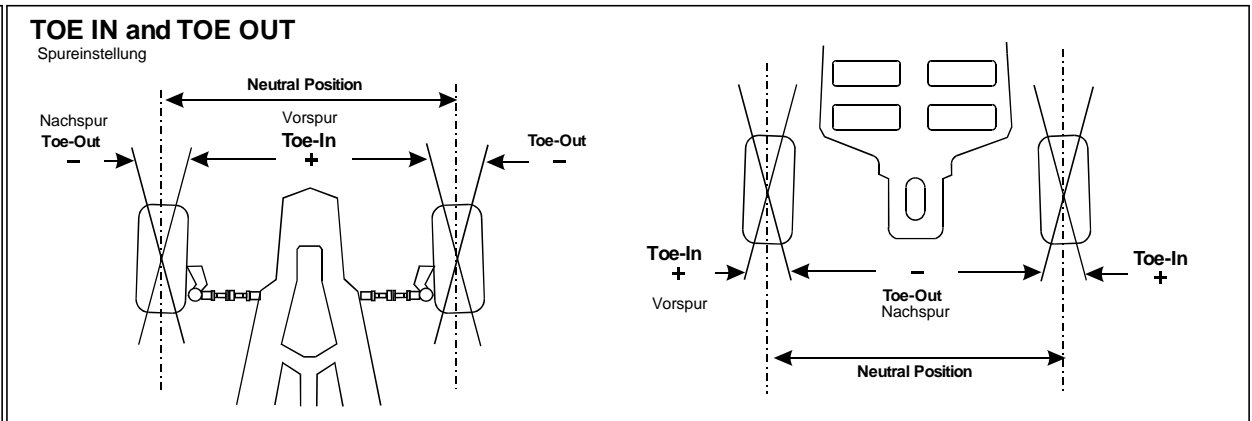

**Front**  
Vorne

X A 9

B

---

**Rear**  
Hinten

X A 5

B

C

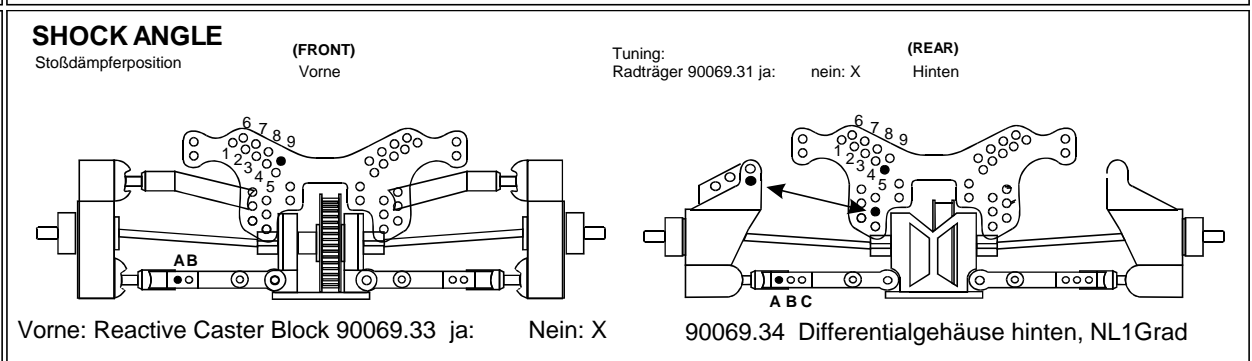

**HARDNESS OF SPRING**  
Federhärte

<b>Front</b> Vorne	<b>Rear</b> hinten	2-Loch klein Kolbenplatte <b>SHOCK OIL</b> Stoßdämpferöl 2 hole piston
GM 1.8mm lila	GM 1.6mm grün/green	

<b>Front</b>	10W	20W	30W	40W	50W	<b>80W</b>
<b>Rear</b>	10W	20W	35W	40W	50W	<b>60W</b>

## SETUP SHEET TC4 International

<b>NAME/</b> Marc Fischer	<b>MOTOR</b> EVO 4 12x3 02er Kohlen	<b>TIRE(F)</b> Graupner 5055.72, soft Einlage96376
<b>DATE/</b> 04.02.2001	Timing 6mm 0.55 Federn	<b>TIRE(R)</b> Graupner 5055.72, soft Einlage96376
<b>CIRCUIT/</b> Teppich Halle Geilenkirchen	<b>SPEEDO</b> V12XC Turbo 0.55 80A	<b>TEMP/</b> 22 °C Auf 24mm Felgen

GEAR RATIO	64 Pitch			48 Pitch			ONE-WAY DIFFERENTIAL	Front Vorne	Center Hinten	
Getriebeuntersetzung	①	②	③	①	②	③		Freilauf		
SPUR GEAR Hauptzahnrad	126 T	126 T	124 T	T	T	T	Nein/No		Nein/No	
PINION GEAR Motorritzel	42 T	41 T	41 T	T	T	T				

		1	2	3	4	5	6	7	8
<b>BEST LAP</b> Rundenzeit	Lap 1	16.40							
	Lap 2								
	Lap 3								
	Lap 4								
	Lap 5								
	Lap 6								
	Lap 7								
	Lap 8								
	Lap 9								
	Lap 10								
	Lap 11								

**REMARKS:**

Bemerkungen:

*GM Alfa 156 Body*

Radstand vorne 2mm verkürzt und hinten 2mm verlängert..